



Industrial
Louvers, Inc.

www.IndustrialLouvers.com

511 South 7th Street

Delano, MN 55328

763-972-2981

Installation Instructions for SA Series, ST Series, XP Series Sunshades

Note:

- The information included in the submittal drawing package shall supersede any information included in these installation instructions. Fastener type, size, and quantity shall be dictated by the submittals. It is the responsibility of the installer to follow all building codes and comply with all safety regulations.
- These installation instructions are intended to cover basic sunshade installation processes. Various surrounding conditions may require a specialized anchorage solution in which case the Industrial Louvers prepared shop drawings should be referenced for installation guidance.
- Anchors into substrate are not supplied unless noted otherwise. The installer is responsible for supplying appropriate anchors.
- The product depicted in these installation instructions may not match the product supplied, however the installation process is the same.

Table of Contents

Definitions / Abbreviations	2
Sunshade Assembly Overview and Component Identification	3
Mounting Bracket Anchorage	4
Suspension Rod Bracket Anchorage	5
Suspension Rod Installation	6
Sunshade Unit Installation	7
Alignment Pin Installation	8
Suspension Rod Tab Installation	9

Definitions / Abbreviations

-Blade

The component used to provide shading throughout the sunshade cross section. Blades span between outriggers.

-Fascia

The outer most component spanning between outriggers.

-Mounting Bracket

The component joining the sunshade outriggers to the building structure.

-Outrigger

The component carrying the blades and fascia. The outrigger transfers loading to the mounting bracket.

-Suspension Rod

Adjustable length support rod.

-Suspension Rod Bracket

The component joining the suspension rod to the building structure.

-Suspension Rod Tab

The component joining the suspension rod to the sunshade outrigger.

Sunshade Assembly Overview

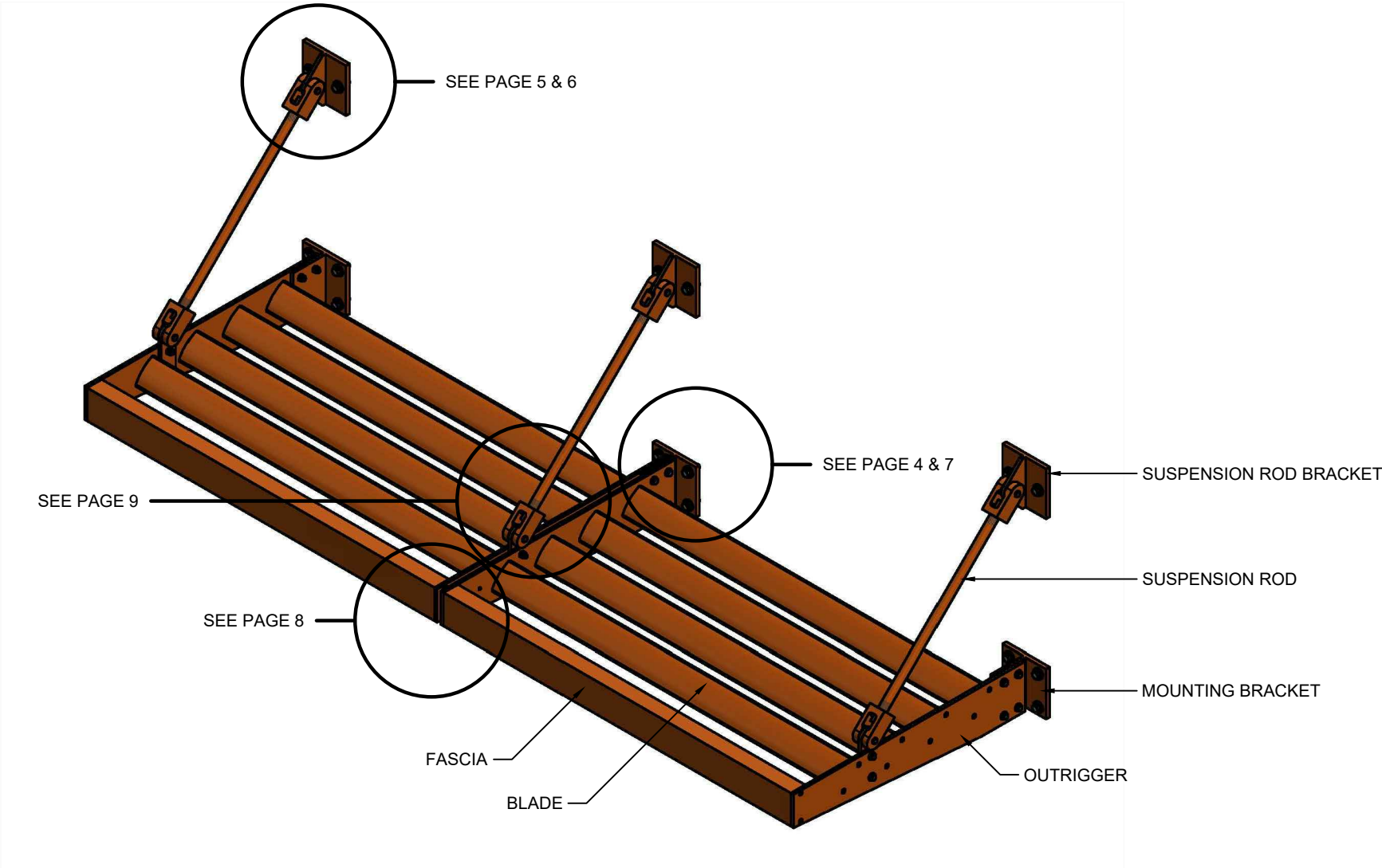

Mounting Bracket Anchorage

1. Make marks at proper elevation for the top and/or bottom of the mounting brackets.
 - Consult the Industrial Louvers prepared submittal drawings and the architectural drawings to determine proper elevation.
2. Snap horizontal lines at marks made in Step 1.
3. Mark the lateral center line location for all mounting brackets.
 - Consult the Industrial Louvers prepared submittal drawings for bracket spacing.
4. Drill pilot holes for anchors.
 - Consult anchor manufacturer's product data for proper substrate preparation.
 - Use mounting bracket as a template.
5. Install anchors per anchor manufacturer's recommendations.

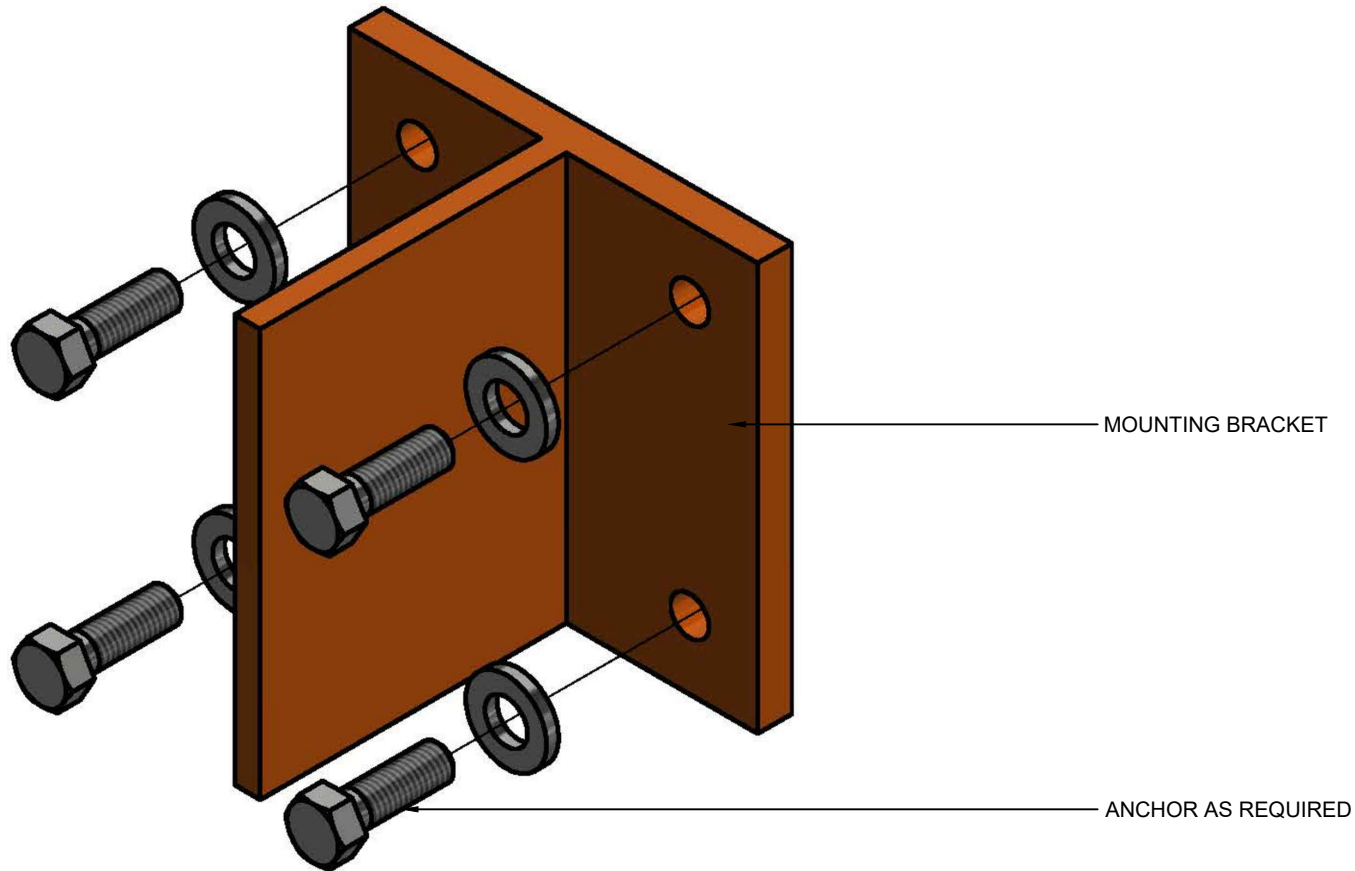

Suspension Rod Bracket Anchorage

Note:

If suspension rods were not supplied skip to page 7.

1. Make marks at proper elevation for the top and/or bottom of the suspension rod brackets.
 - Consult the Industrial Louvers prepared submittal drawings and the architectural drawings to determine proper elevation.
2. Snap horizontal lines at marks made in Step 1.
3. Mark the lateral center line location for all suspension rod brackets.
 - Consult the Industrial Louvers prepared submittal drawings for bracket spacing.
4. Drill pilot holes for anchors.
 - Consult anchor manufacturer's product data for proper substrate preparation.
 - Use bracket as a template.
5. Install anchors per anchor manufacturer's recommendations.

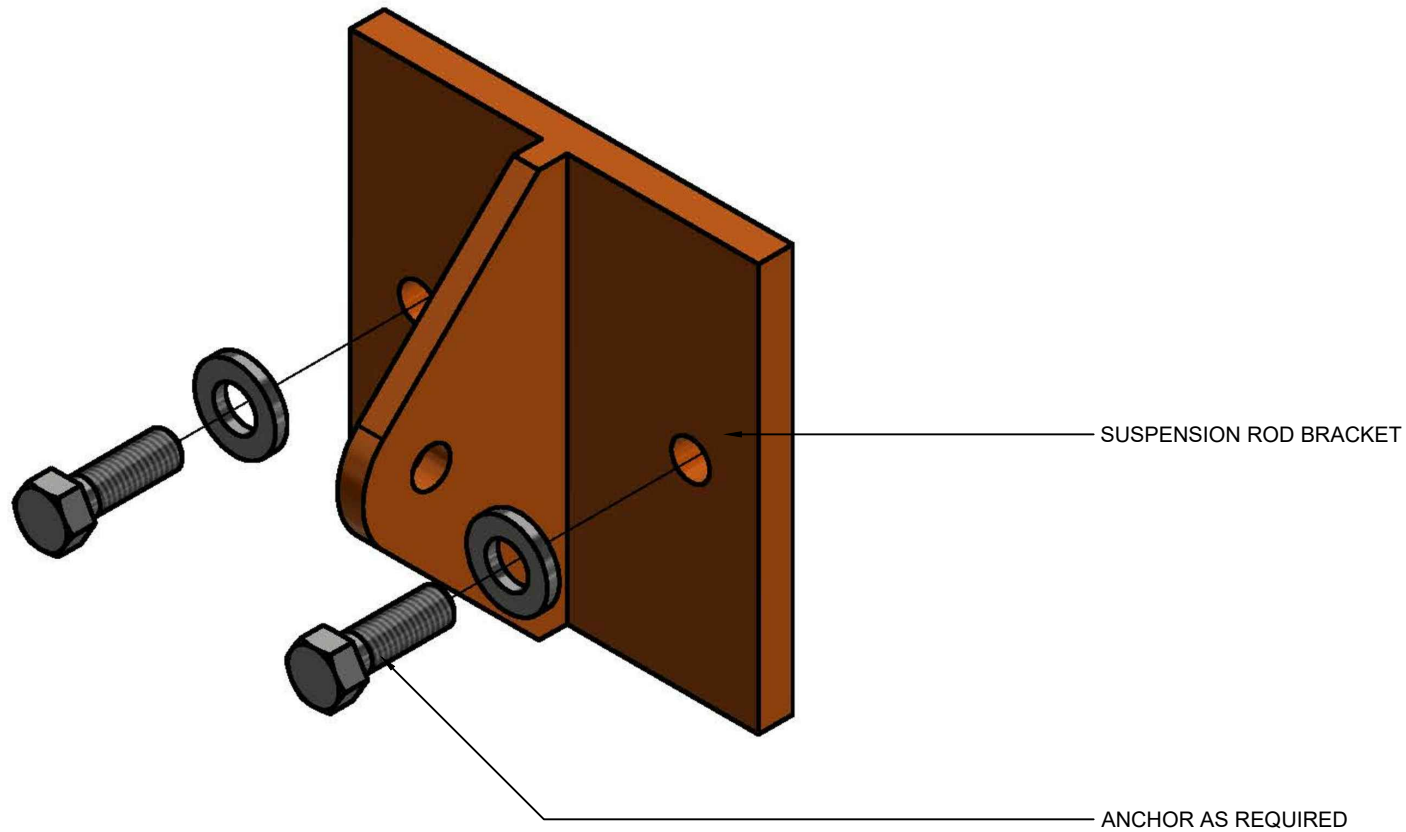

Suspension Rod Installation

- 1. Install one suspension rod assembly at each suspension rod bracket with 1/2" diameter clevis pins and cotter pins.

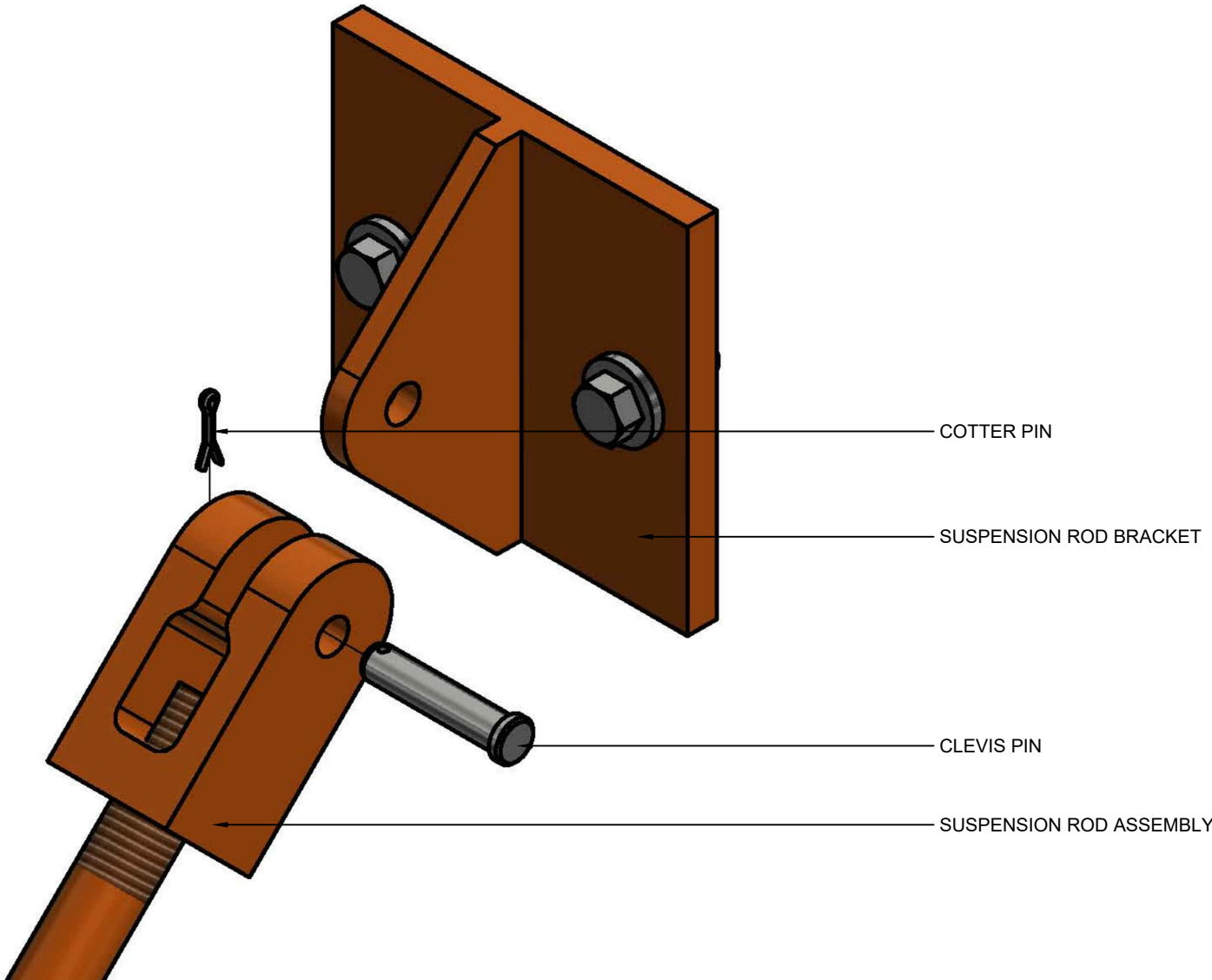

Sunshade Unit Installation

1. Position sunshade units appropriately.
 - Make sure unit is level.
 - Unit must be situated at the correct projection.
 - Unit must be situated at the correct elevation.
2. Match drill holes in sunshade outriggers thru mounting bracket knife plate.
 - Drill tight fit clearance holes to prevent excessive sag.
3. Install thru bolts.

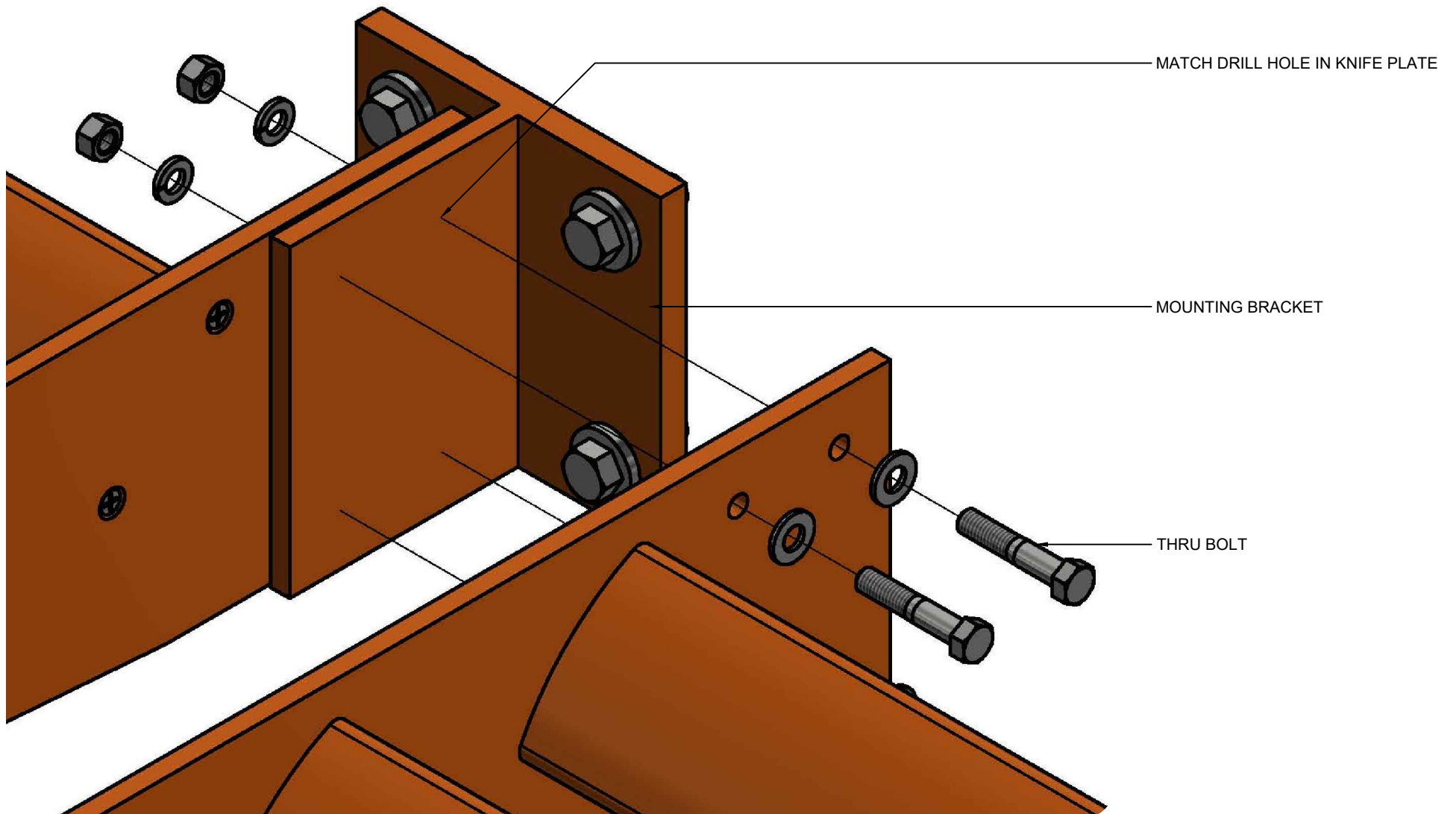

Alignment Pin Installation

Note:
If alignment pins were not supplied skip this page.

- 1. Install alignment pins thru factory drilled holes in outriggers.
 - The hole in one outrigger will be clearance fit, and the hole in the other outrigger will be tight fit. A hammer or clamp may be required to aid pin installation.

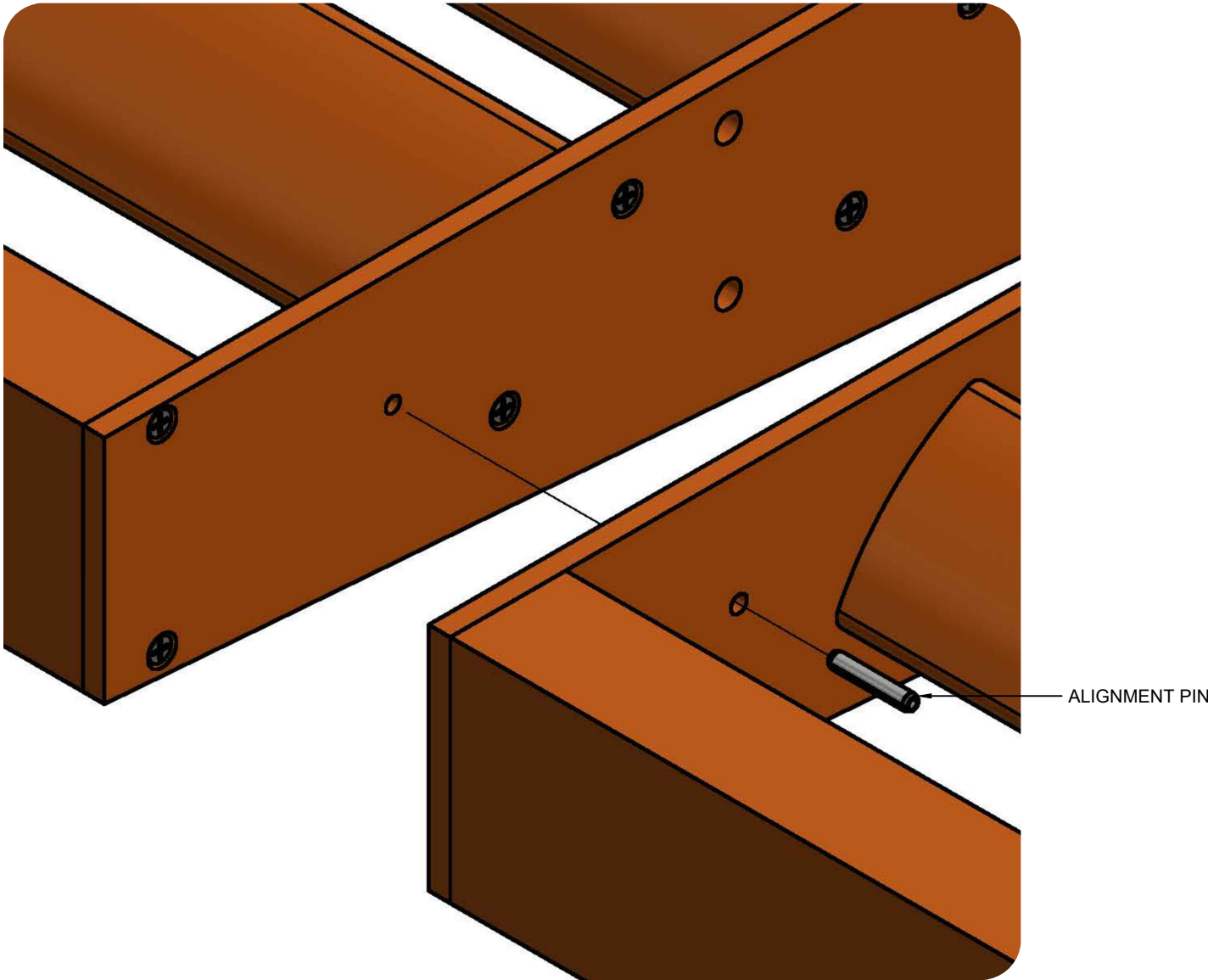

Suspension Rod Tab Installation

Note:

If suspension rods were not supplied skip this page.

1. Install one suspension rod tab at each location as shown in the Industrial Louvers prepared submittal drawings.
2. Install suspension rod assembly onto tabs with 1/2" diameter clevis pin and cotter pin.
- Adjust length of suspension rod as necessary.

