

MODEL 650XP

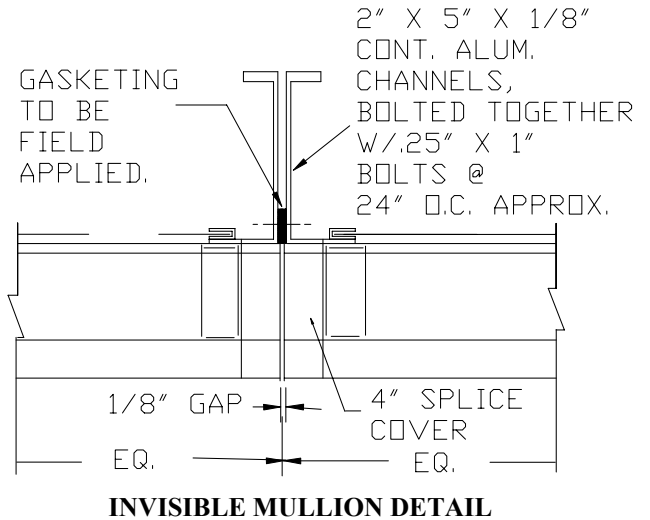
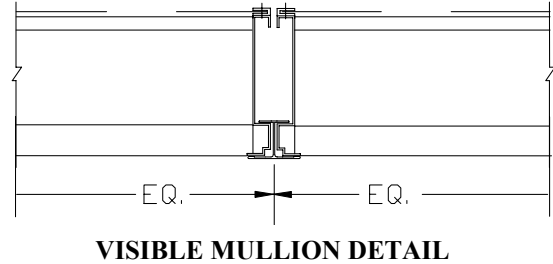
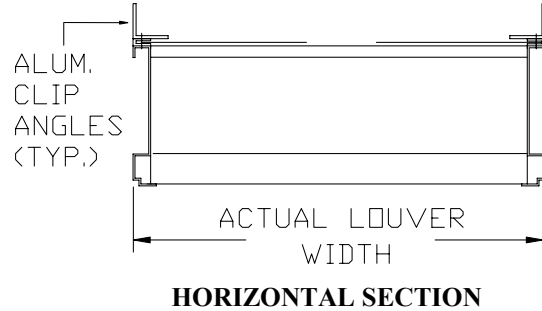
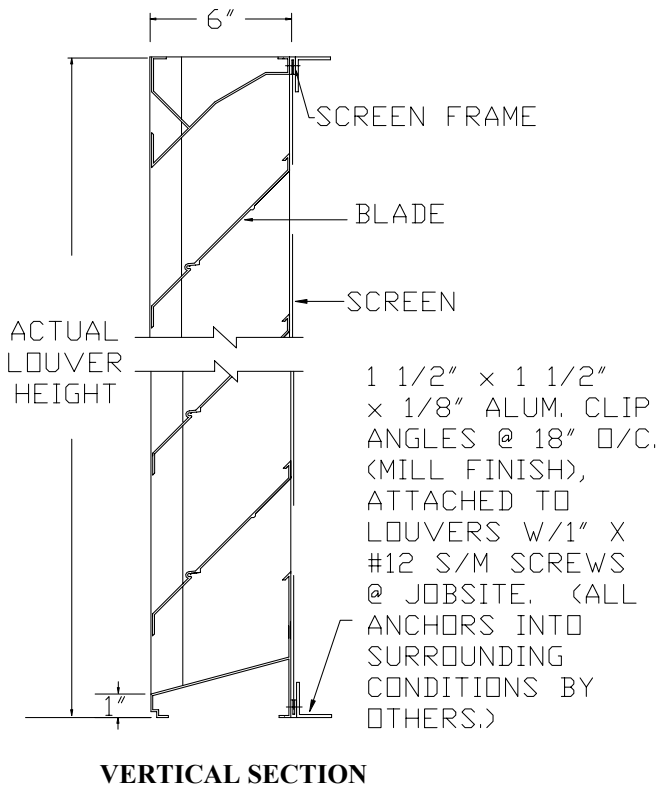

ACCESSORIES:

- SILL FLASHING - DEPTH _____
- SCREEN _____
- FINISH _____
COLOR _____
- OTHER _____

ITEM NO.	QTY	SIZE	Actual	M.O.	MULLION TYPE	NO. OF SECTIONS	REMARKS
		WIDTH	HEIGHT				

PROJECT _____ REPRESENTATIVE _____

LOCATION _____ ILI JOB NO. _____ REP NO. _____

ARCH/ENGR. _____

Industrial Louvers, Inc. Phone: 763-972-2981
511 South 7th Street Fax: 763-972-2911
Delano, MN 55328

CONTRACTOR _____

DATE _____

CATALOG NO. 650XP Rev: JANUARY 2004